

RT1 - 750kg

Single Axle Unbraked Trailer

Trailer chassis is suitable for most brands of generators and other static plant such as tanks, pumps, compressors and other.

Optional extra: Pin hitch

Features

- Ready for work rolling chassis
- Towable chassis is fully certified and approved and is recorded on a data base in accordance with Regulation 2007/46/EC
- Open frame design
- The design is approved for various load fastening variations
- Chassis is complete with mudguards and rear lights

Benefits

- Simply load and secure your equipment and go
- No further testing or certification is required as the standard issue certification satisfies all the elements of trailer legislation and chassis can be legally and safely towed with, or without a payload
- Simply fasten and secure your generator or equipment on and off the chassis with ease
- Choose from ratchet straps or nut and bolts fasteners as both are acceptable
- Trailer is suitable for UK and Ireland highway use

Maximum towable weight of **750kg**

Suitable for most brands of generator up to **15kVA**,* including the following MHM models:

STAGE 5 ENGINE	STAGE 3 ENGINE
MG 6000 SSY-5-ECO	MG 6000 SSK
MG 6000 SSY-5	MG 8000 SSK
MG 6000 E/SSY-5	MG 10000 SSK-ECO
MG 8000 SSKH-5	MG 10000 SSK
MG 10000 SSKH-5-ECO	MG 10000 SSK-3PH
MG 10000 SSKH-5	MG 15000 SSK-MV
MG 10000 SSKH-5-3PH	
MG 15000 SSY-5-MV	



Specification

Tow Hitch Type:	Ball	Suspension:	Yes	Jockey Wheel:	Yes
Wheel Quantity:	2	Brakes:	No	Mudguards:	Yes
Wheel Size:	10 inch	Handbrake:	No	Tail Lights:	Yes
Tyre Size:	145/80 R10	Breakaway Cable:	No		

Dimensions (Trailer)

Length:	2650 mm	Width:	1300 mm	Height:	700 mm
Weight:	135 kg	Max. Load / Bed Weight:	615 kg		
Max. Bed Area:	815 mm ²	Max. Gross Vehicle Weight (GVW):	750 kg		

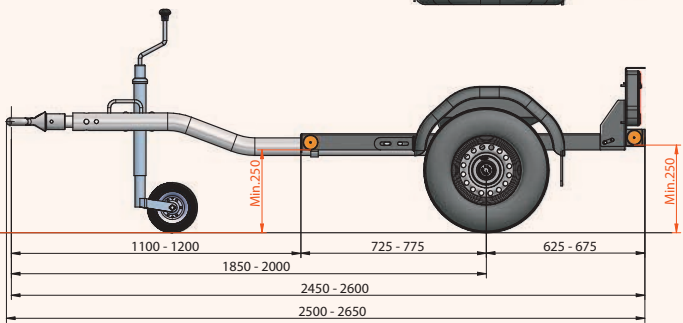
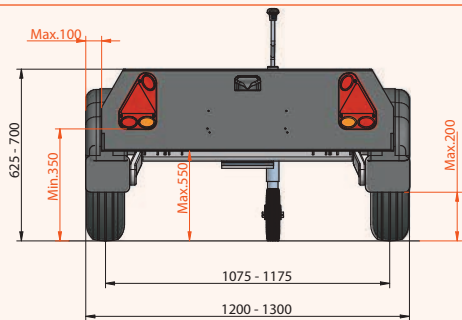
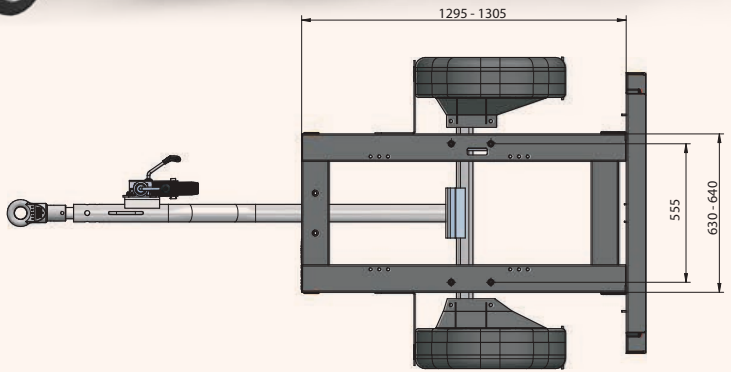

For more details call **MHM TODAY** on **0808 168 9099**

Email sales@mhmplant.com or visit us at www.mhmplant.com

Designed in the UK, built in Italy